



General Safety Company LTD.

Industrial Machines Safety: Components and Solutions

2175 Sheppard Ave. East Unit 250, Toronto, Ontario, M2J 1W8

Tel. (416) 645-0242 Fax. (416) 447-0091







www.generalsafety.ca info@generalsafety.ca

PRESENTS

THE COMPLETE GUARDING SOLUTION

Protecting operators from the hazards generated by working equipment and machines is of number one importance to all employers.

That's why we've dedicated this catalog to state of the art safety guards systems. With products ranging from lathe guards to grinder guards you'll find everything you need to protect your work room as well.

	Guards for your Lathes	Pages 2-8
	Milling Machines Guards	Pages 8-14
	Drill Press Guards	Pages 14-15, 17
	Band Saw and Scroll Saw Guards	Pages 16
	Splash, Chips and Spark Guards	Pages 18-22
	Sander Guards	Page 24

	Grinder Guards	Pages 23-24
	Table Saw Guards	Pages 28-29
	PanelGuard – Modular Machine Guarding System	Pages 28-29
	Motor Control	Pages 25, 30
	Industrial Safety Mats	Page 31
	Machine Lamps	Page 32

Safety is our Specialty!



General Safety Company LTD.

Industrial Machines Safety: Components and Solutions

2175 Sheppard Ave. East Unit 250, Toronto, Ontario, M2J 1W8
Tel. (416) 645-0242 Fax. (416) 447-0091

GET ON THE TRACK WITH

SLIDE-TRACK LATHEGUARD

(Sliding Lathe Shields)

Heavy-Duty 14 Gauge Steel Shields with LEXAN® windows mount over headstock and slide over chuck for maximum protection! Allows easy access to the point of operation when power is off.

FITS CONVENTIONAL LATHES AND CNC MACHINES
TWO STYLES AVAILABLE: "MINOR" AND "MAJOR"

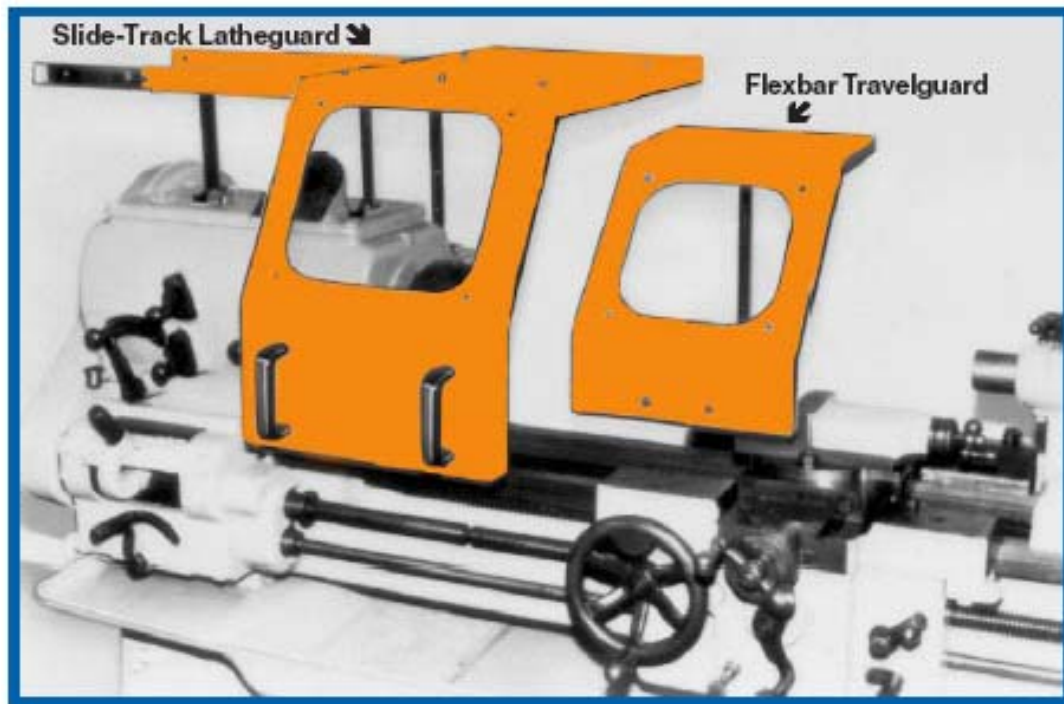

Above: "MAJOR" SLIDE-TRACK LATHEGUARD (left) with FLEXBAR TRAVELGUARD (right - See Page 8)

- The "Minor" Slide-Track Latheguard features two (2) 3/16" thick LEXAN® windows. Being situated on the top and front inclined panels, these windows provide excellent visibility for the operator. The front panel hinges up to allow access to the controls and settings of the machine - The "Minor" is designed to guard lathes having chucks ranging from 10" diameter up to 24" diameters.
- The "Major" Slide-Track Latheguard provides maximum operator protection on standard machines or large CNC lathes with chucks ranging up to 48" diameter. These guards incorporate one LEXAN® front panel window and do not require a top window.

SHIELDS SUPPLIED WITH ORANGE BAKED ENAMEL PAINTED FINISH FOR LONG WEAR

Safety is our Specialty!



General Safety Company LTD.

Industrial Machines Safety: Components and Solutions

2175 Sheppard Ave. East Unit 250, Toronto, Ontario, M2J 1W8
 Tel. (416) 645-0242 Fax. (416) 447-0091

SLIDE-TRACK LATHEGUARD

SPECIFICATIONS AND ORDERING:

You can now install a professional heavy-duty guard on any size lathe. Simply screw the 4 pillar posts supplied at 4 sites around the headstock and then slip on the track assembly chassis. Now mount the shield. Pillar posts, in relation to cross members are adjustable vertically hence easily positioned around the headstock without interference. *All hardware is included with easy-to-follow instructions.*

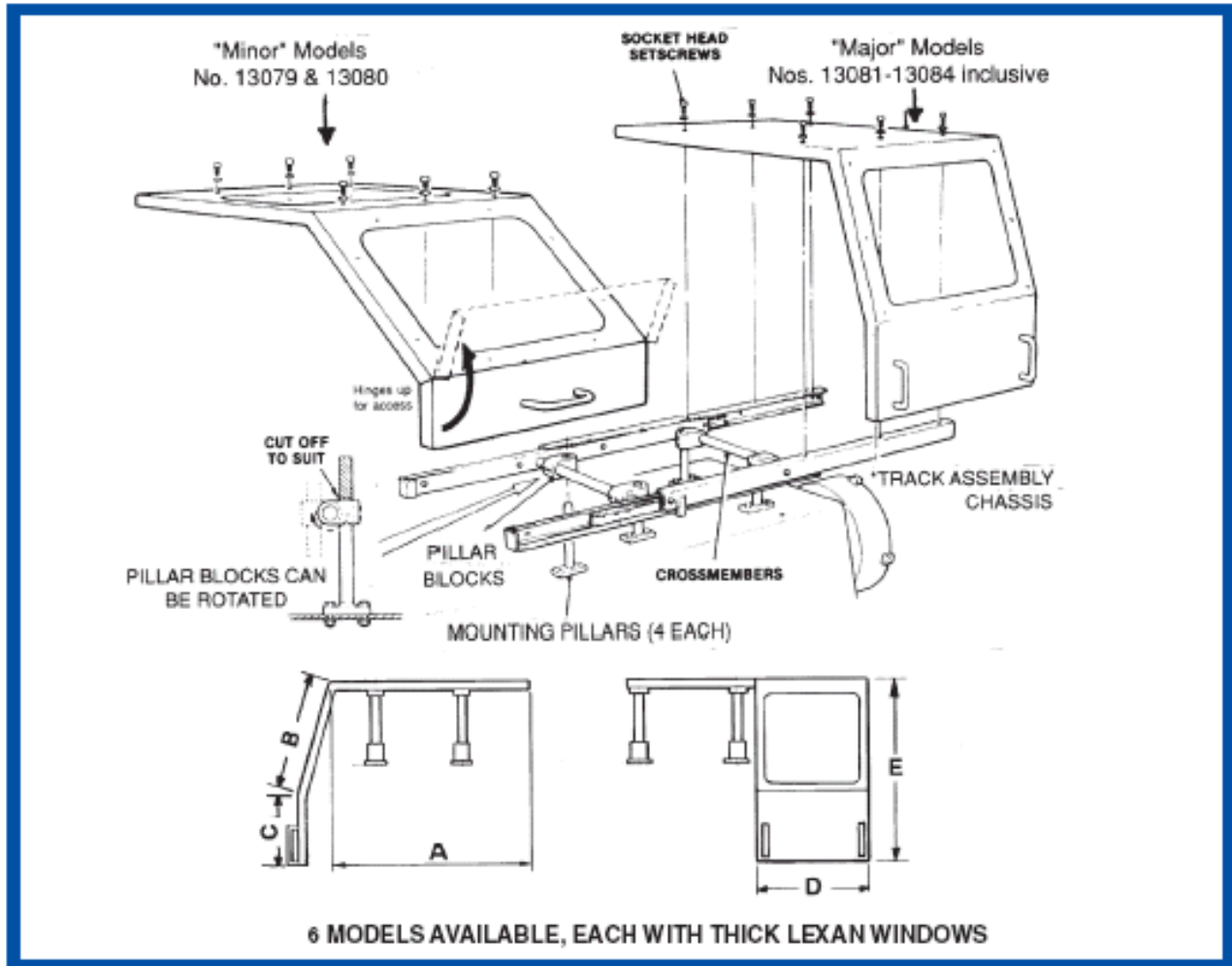

Model No.	Chuck Capacity	Dimensions				
		A	B	C	D	E
<u>13079</u>	24"	17"	19"	6"	14"	17.75"
<u>13080</u>	24"	17"	19"	6"	24"	17.75"
<u>13081</u>	28"	26"	14.88"	8.24"	19.75"	21.10"
<u>13082</u>	32"	27.19"	16.50"	8.71"	19.75"	23.00"
<u>13083</u>	40"	29.56"	19.75"	9.81"	19.75"	26.90"
<u>13084</u>	48"	33.88"	23.00"	10.85"	19.75"	30.75"

(*SUPPLIED COMPLETELY ASSEMBLED) REPLACEMENT WINDOWS AND PARTS SUPPLIED UPON REQUEST

Safety is our Specialty!



General Safety Company LTD.

Industrial Machines Safety: Components and Solutions

2175 Sheppard Ave. East Unit 250, Toronto, Ontario, M2J 1W8
Tel. (416) 645-0242 Fax. (416) 447-0091

Prevent Accidents With

LATHEGUARD

MADE OF
***LEXAN®**
Certified



Clear LEXAN, Semi-Circular Wrap-a-round Guards

- Heavy Duty Cast Mounting bracket supplied.
- Heavy Duty Chrome-plated extension tube and hardware.
- Ready to mount; all you do is affix mounting bracket with two screws.
- Back of shield is reinforced with plated wire-form housing.
- Locks in swing away or functional positions.
- Accepts 3 or 4-Jaw Chucks.

**NEITHER
RAZOR-SHARP CHIPS NOR
BROKEN TOOL BITS WILL
PENETRATE THE LEXAN® SHIELD**

Model No.	Suggested Lathe Size	Center Height (A) (Shield Height)	Use With Chucks	Shield Width (F)	Shield Length (B)	Tube Length (E)
<u>12999</u>	Very Small Lathes	3.9"	Up to 6" Dia	6 1/4"	7.8"	10"
<u>13060</u>	6 to 12	6"	Up to 8" Dia	6 1/4"	11.8"	10"
<u>13061</u>	12 to 16	8"	Up to 12" Dia	8"	15.8"	11 1/2"
<u>13062</u>	16 to 20	10"	Up to 16" Dia	8"	19.70"	13"
<u>13064</u>	20 to 24	13"	Up to 20" Dia	8"	23.6"	13"
<u>13059</u>	Extra Long Tube (E) for lathes where chuck sticks out a long way from headstock					16"

REPLACEMENT SHIELDS AVAILABLE. SEE NEXT PAGE.

*ALL LATHEGUARDS SUPPLIED WITH MOUNTING BRACKET NO. 13070

Order from below if your Lathe needs either #13068 or #13069 Bracket, or No. 13071 Double Bracket

Model No.	Description
<u>13068</u>	For mounting to top or back of headstock.
<u>13069</u>	Extension or telescoping type for top or back mounting.
<u>13070</u>	If you want an extra mounting bracket.
<u>13071</u>	Double bracket: this enables you to mount the next larger shield when changing from a 3 jaw chuck to a 4 jaw chuck.
<u>13075</u>	Long Reach Latheguard Mounting Kit for easy mounting of Latheguard on large machines or difficult applications. Mount can be positioned up to 27" from Latheguard.



*REG. TRADEMARK OF GENERAL ELECTRIC CO.

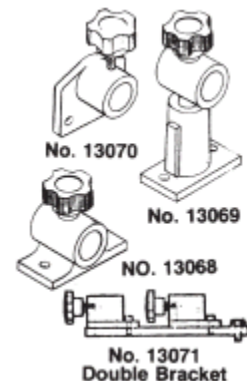

Safety is our Specialty!



General Safety Company LTD.

Industrial Machines Safety: Components and Solutions

2175 Sheppard Ave. East Unit 250, Toronto, Ontario, M2J 1W8
 Tel. (416) 645-0242 Fax. (416) 447-0091

THE LEXAN LATHEGUARD

Information and Specifications

HINTS, FOR SELECTING THE CORRECT LATHEGUARD!

- (1) The Chuck Diameter being used on your Lathe makes for a good formula.
- (2) Utilize Dimension "A" and other dimensions given in chart shown below.
- (3) On Lathes with center heights of 7 inches or more there is a significant variation in the diameter of a 3-Jaw as against a 4-Jaw Chuck. It may be necessary to install the next larger Latheguard to accommodate for the 4-Jaw Chuck. Keeping a double bracket (No. 13071) on the Lathe makes it possible to switch your latheguard from small to larger size)and vice versa, in one minute.

**NEITHER RAZOR-SHARP CHIPS NOR BROKEN TOOLS BITS
 WILL PENETRATE THE LEXAN SHIELD**

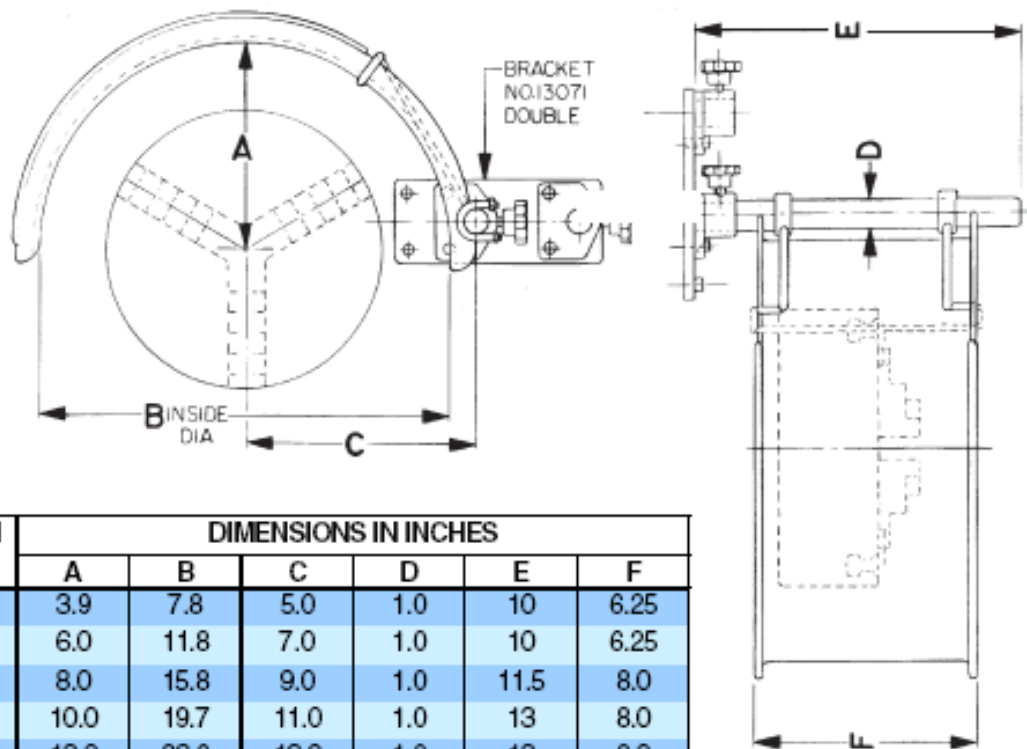

Model No.	DIMENSIONS IN INCHES					
	A	B	C	D	E	F
<u>12999</u>	3.9	7.8	5.0	1.0	10	6.25
<u>13060</u>	6.0	11.8	7.0	1.0	10	6.25
<u>13061</u>	8.0	15.8	9.0	1.0	11.5	8.0
<u>13062</u>	10.0	19.7	11.0	1.0	13	8.0
<u>13064</u>	13.0	23.6	12.9	1.0	13	8.0

REPLACEMENT SHIELDS (only) for LATHEGUARD

Model No.	Shield Width (F)	Shield Height (A)	Shield Height (B)	Replacement For Latheguard Model No.
<u>13072</u>	6 ¼"	7.8"	3.9"	<u>12999</u>
<u>13065</u>	6 ¼"	12"	6"	<u>13060</u>
<u>13066</u>	8"	16"	8"	<u>13061</u>
<u>13063</u>	8"	19.70"	10.25"	<u>13062</u>
<u>13067</u>	8"	24"	12"	<u>13064</u>

Safety is our Specialty!



General Safety Company LTD.

Industrial Machines Safety: Components and Solutions

2175 Sheppard Ave. East Unit 250, Toronto, Ontario, M2J 1W8
Tel. (416) 645-0242 Fax. (416) 447-0091

LATHEGUARD INTERLOCKS

Electrical Interlocking Mounting Brackets

For use with all Flexbar Latheguards and
Small Chuckguards (see p. 4 & 7)
4 MODELS AVAILABLE TO SUIT INDIVIDUAL LATHE DESIGNS

Functioning: Once wired to motor-control circuit (motor starter), the cam-operated limit switch opens the contacts when the safety shield is tilted up . . . and the machine stops running (see fig. 1 and fig. 2).



fig. 1

E.I.M.B. Housing:

- Heavy-duty casting
- Bright yellow painted finish

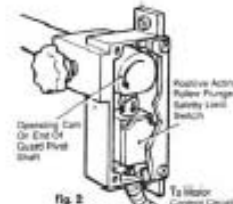

fig. 2

SPECIFICATIONS

Limit Switch:

- Roller-type
- Roller and head are metal in sealed plastic housing
- Electrical life - 1 million cycles
- Mechanical life - 30 million cycles
- NEMA 4 rated
- Approvals: ULA300, ULE140497, CSA A 300 & CSA LR26716 M20
- Snap acting SPDT INO-INC with double break ensures switch will open event of minor contact welding
- Contact block & roller head are modular hence replaceable without discarding entire device



Electrical Conduit:

- Extremely flexible and withstands repeated flexing
- recognized - exceeds industry standards
- Liquid tight vs. oil, water and most chemicals
- certified and recognized
- **Fittings:** Inside is nylon with BUNA-N gland which seals the two each (2) 18 gage wires, plus a grounding wire.

AVAILABLE IN 4 DIFFERENT MOUNTING STYLES:

- Bright Yellow Painted Finish

Included with each E.I.M.B. model:

- Electrical Interlock Box with safety limit switch, wiring and mounting bracket with locking knob
- Special Latheguard tube
- Wiring diagram.

Dimensions of rectangular box portion of E.I.M.B.:
Approx. 6-5/8 X 2-3/8 X 1-5/8 inches (168mm x 60mm x 41.3mm)



Model No. 17002 (Style 2)
Style 2 - Telescoping & Swiveling Style.
For lathes with irregular or dome-shaped headstock, E.G.- Hardinge.
For all shield sizes.



Model No. 17003 (Style 3)
Style 3 - Mounts on face of headstock. Backplate can be reversed 180° on housing thus flange portion can be on right (as shown) or on left side, if reversed. All shield sizes.

Flange
(Reversible)



Model No. 17004 (Style 4)
Style 4 - Top mounting for flat top of headstock. All shield sizes.
NOTE: Observing the lathe structure and taking a few measurements makes proper selection easy.

ABOVE E.I.M.B. MODELS DO NOT INCLUDE LATHEGUARD SHIELDS/ASSEMBLIES.
REFER TO PAGES 4 & 7 TO ORDER LATHEGUARDS.

Safety is our Specialty!



General Safety Company LTD.

Industrial Machines Safety: Components and Solutions

2175 Sheppard Ave. East Unit 250, Toronto, Ontario, M2J 1W8
Tel. (416) 645-0242 Fax. (416) 447-0091

THE SMALL CHUCKGUARD

Designed For Heavy Duty Applications Where a Steel Shield Is Recommended On Lathes Up To 20" Diameter



See Through Lexan® Window

Heavy Gauge Steel Bright Safety Painted Finish

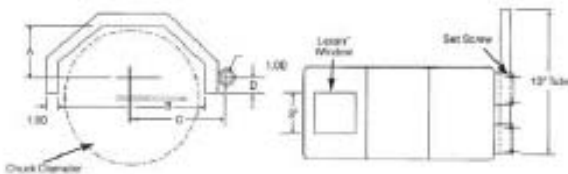

Special Features:

- Available with Flexbar Electrical Interlocking Mounting Brackets (see page 6).
- Heavy-Duty Cast Mounting Bracket supplied (Model No. 13070).
- Optional Mounting Brackets for various applications are available (see page 4).
- Heavy-Duty Chrome-plated Extension Tube and Hardware.
- Ready to mount; All you do is affix mounting bracket with two screws.
- Locks in swing away or functional positions.
- Accepts 3- or 4-Jaw Chucks (Note: Some 4-Jaw Chucks may require a larger size).

INCLUDES HARDWARE & MOUNTING BRACKET No. 13070

Model No.	Center Height (Shield Size)	Use with Chucks	C	Shield Length
13250	9.5"	Up to 16" dia.	10.25"	19"
13251	10.5"	Up to 20" dia.	12.25"	21"
13059	Extra Long Tube (16") for Lathes where Chuck			

CHUCKGUARD SUPER HEAVY DUTY STEEL GUARDS

Made of 14 Gauge Steel for Chucks up to 47" Diameter



Large Diameter Chucks are, by themselves **DANGEROUS!** (Even more so at high speed settings.) Chuckguard protects the operators and the "passer-by" from serious injuries. **Each Chuckguard is supplied complete with mounting hinge, plate and support bar for mounting on headstock of lathe.**

Features:

- Hinged front panel allows easy access to the chuck
- Lexan window for easy viewing
- Comes complete with mounting bracket and support bar for mounting on headstock
- Bright safety painted finish
- Exceeds O.S.H.A. requirements

Quick Reference Guide for Selecting Correct Steel **Chuckguard**

Custom Built heavy gauge steel chuck shield available for very large diameter chucks up to 62".

Model No.	Dimensions			Chuck Diameters
	A	R	L	
13056	14"	17 1/2"	35"	20", 24", 25", 26", 28", 30", 30 1/2"
13057	14"	20"	40"	30 1/2", 32", 36"
13058	14"	25 1/2"	51"	39 1/2", 47", 49"

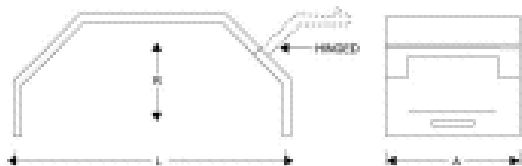

Safety is our Specialty!



General Safety Company LTD.

Industrial Machines Safety: Components and Solutions

2175 Sheppard Ave. East Unit 250, Toronto, Ontario, M2J 1W8
Tel. (416) 645-0242 Fax. (416) 447-0091

TRAVELGUARD

CROSS SLIDE TYPE

EXTRA-HEAVY DUTY O.E.M. TYPE FOR LATHES, GRINDING MACHINES, ETC. TRAVELS WITH CROSS SLIDE OPERATOR PROTECTION WHEREVER TOOL IS CUTTING

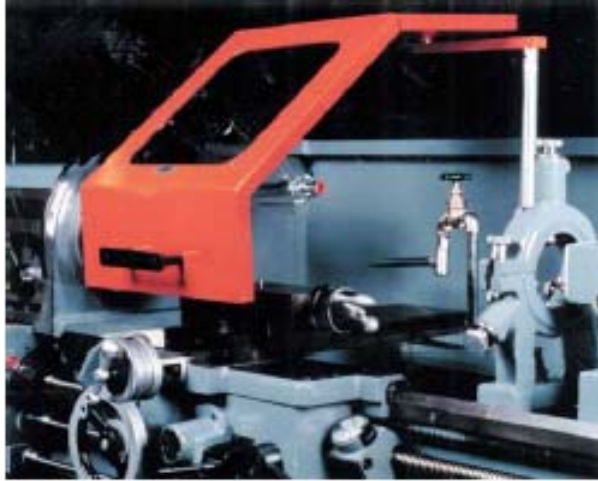

- Easy to mount on cross slide (tool compound).
- Fully adjustable in all directions—forward & frontward.
- Heavy steel construction with thick lexan window.
- Frame is 3/4" construction made of heavy gauge steel with high quality painted finish.
- Front panel is hinged and can be lifted for quick access to machine.

Model No. 13086 - 20" Chuck Max

Model No. 13087 - 28" Chuck Max

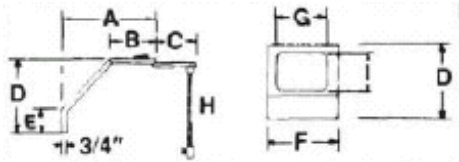
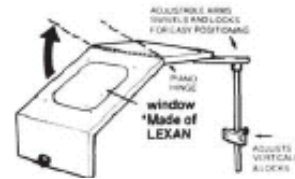

Model No.	A	B	C	D	E	F	G	H	I
13086	16	8	7 3/4	13	4	11 7/8	8 1/2	20 1/2	8 1/2
13087	22 3/4	10 1/2	9 3/4	14 1/2	5 5/8	14	9 3/4	20 1/2	10 3/4

LATHE CHUCK SAFETY WRENCHES

Spring-loaded, self-ejecting chuck wrenches designed for use with lathes and other machines equipped with manually adjusted chucks.



- Spring-load sleeve ejects the wrench from the chuck after each use
- Chamfered end for easy entry
- Designed to provide proper loads for self-removal of the wrench weight
- **Helps prevent accidents**

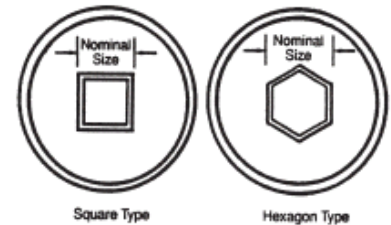

Model No.	Nominal Size	Actual Size	Bar Dia.	Overall Dia.	Engagement Length
15470	9/32" SQ	.271"	3/4"	1.050"	3/4"
15471	5/16" SQ	.303"	3/4"	1.050"	3/4"
15472	3/8" SQ	.365"	3/4"	1.050"	3/4"
15473	7/16" SQ	.427"	3/4"	1.050"	3/4"
15474	1/2" SQ	.490"	3/4"	1.050"	3/4"
15475	1/2" HEX	.490"	3/4"	1.050"	3/4"
15476	5/8" HEX	.615"	3/4"	1.050"	3/4"
15477	9/16" SQ	.552"	15/16"	1.315"	3/4"
15478	5/8" SQ	.615"	15/16"	1.315"	3/4"
15479	11/16" SQ	.678"	15/16"	1.315"	3/4"
15480	3/4" SQ	.740"	15/16"	1.315"	3/4"
15481	3/4" HEX	.740"	15/16"	1.315"	3/4"

Safety



General Safety Company LTD.

Industrial Machines Safety: Components and Solutions

2175 Sheppard Ave. East Unit 250, Toronto, Ontario, M2J 1W8
Tel. (416) 645-0242 Fax. (416) 447-0091

UNIVERSAL MOUNT MILL & GRINDER GUARD

Heavy Duty Steel Frame With Lexan Guards
For Milling Machines and Unguarded Machines Including
C.N.C.'s, Multi-spindles and Grinders
FULLY ADJUSTABLE WITH LONG REACH OPTION AVAILABLE



In use: Guard down



Flip up to change work piece or
tool...no loss in productivity!

Unique universal positioning design is fully adjustable. Frame/shield is mounted and supported by a heavy duty arm and swivel clamp thus allowing the operator to "custom fit" each guard as to overall length, angle and position of shield. Wing-shaped frame/shield protects workers at adjacent machines. Long Reach Extension Kit Model **No. 13262** permits positioning of guard up to 40" from mounting point.

- Easy to mount (brackets supplied for most mountings).
- Frame is heavy steel construction with thick Lexan windows.
- High quality painted finish - Bright OSHA color.

Two Sizes Available: Model No. 13258, 19"Wx16"H and Model No. 13260, 26½"Wx16"H

Ordering:

Model No. 13258, Universal Mount Mill/Grinder Guard with 19" W x 16" H heavy duty shield

Model No. 13259, Replacement Lexan window for 13258

Model No. 13260, Universal Mount Mill/Grinder Guard with 26½" W x 16" H heavy duty shield

Safety is our Specialty!



General Safety Company LTD.

Industrial Machines Safety: Components and Solutions

2175 Sheppard Ave. East Unit 250, Toronto, Ontario, M2J 1W8
Tel. (416) 645-0242 Fax. (416) 447-0091

Model No. 13261, Replacement Lexan window for 13260

Model No. 13262, Long Reach Extension Kit for Model Nos. 13258 and 13260. Includes adjustable extension arm and all connection and mounting hardware

TOTALGUARD SLIDE AND SWING ASIDE MILLING MACHINE GUARDS FULLY ADJUSTABLE FOR VERTICAL, HORIZONTAL AND C.N.C. MILLS

ALL PANEL HEIGHTS NOW 23⁵/₈" TALL:
ACCEPTS LARGER PARTS SAFELY

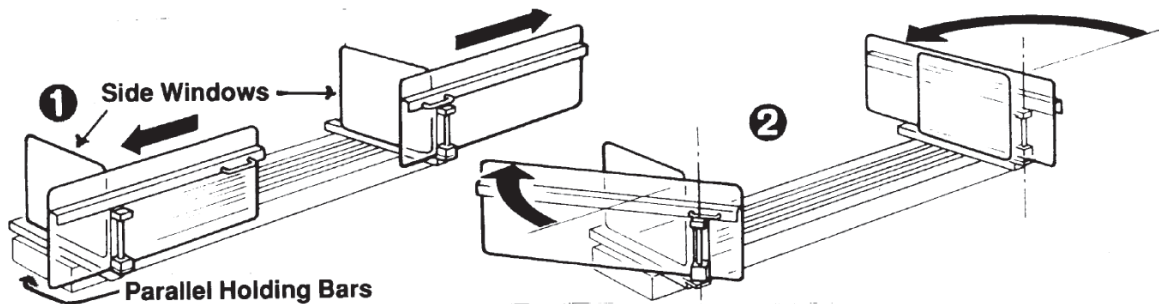
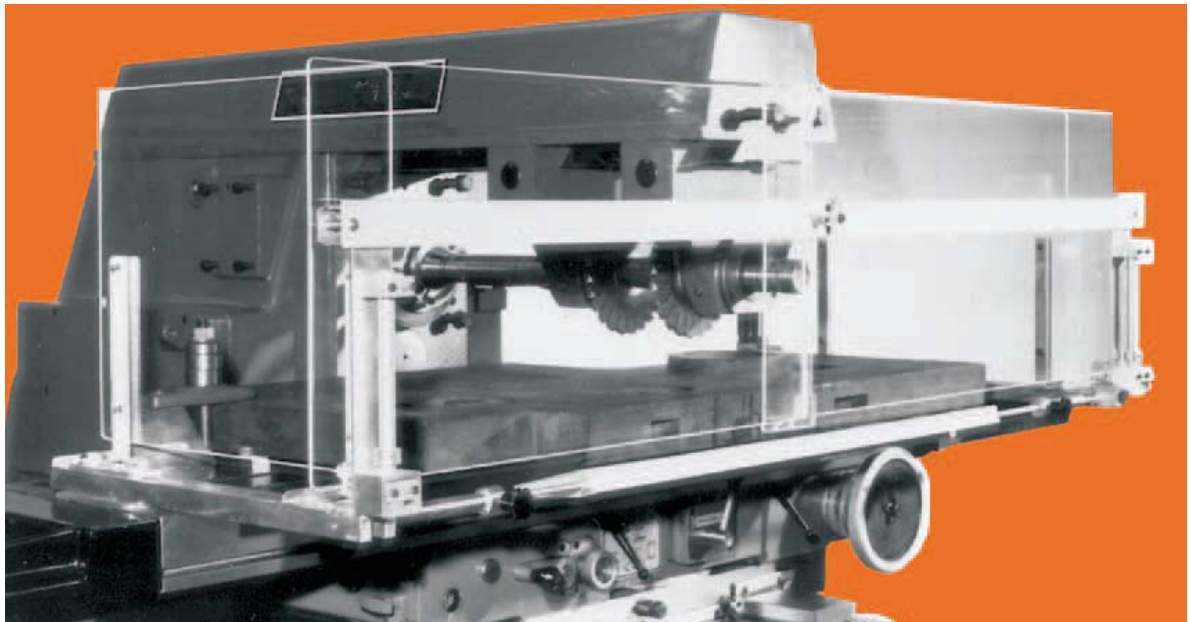

Unique construction allows the front panels to slide and swing aside revealing the whole of the table bed

The Totalguard is supplied in two separate assemblies which are mounted at either end of the table in just minutes. Model nos. 13089 and 13090 consist of two fixed side panels and two front sliding panels which allow the operator quick and easy access for loading and unloading large parts and castings.

Safety is our Specialty!



General Safety Company LTD.

Industrial Machines Safety: Components and Solutions

2175 Sheppard Ave. East Unit 250, Toronto, Ontario, M2J 1W8
Tel. (416) 645-0242 Fax. (416) 447-0091

Model no. 13088 utilizes one front sliding panel and one hinged front panel as well as two fixed side panels. Fully adjustable, the parallel holding bars (see above) enable the guard to move backwards and forwards to cater for vises or parts that overhang the table.

TOTALGUARD

FEATURES:

- Fits all milling machines, horizontal or vertical and C.N.C. mills as well.
- Takes up no more than exact width of table.
- Lexan® panels are crystal clear — good and thick and 25 times stronger than safety glass.
- Panels slide and swing aside quickly and smoothly for making setups; loading and unloading.

- Unlike patch quilt-type mill guards, still on the market, Totalguard does not have slots or apertures for hot chips to sneak through.
- Universal Mounting: Special tee-slot slugs fit all sizes of tee-slots so that Totalguard is installed in less than 5 minutes.
- All Lexan® panels butt together like a perfect window when closed yet reveals the entire table bed when opened.

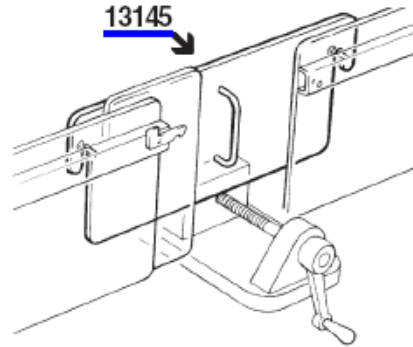
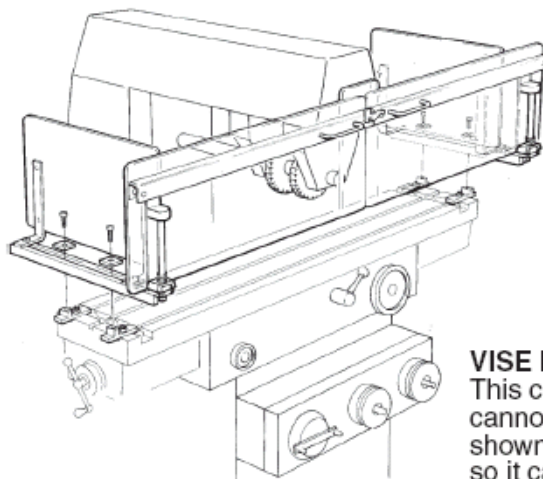

VICE PANEL (optional for 13089 & 13090)

This clear panel covers the gap left when the two front panels cannot be closed completely due to a protruding vise as shown. The guard simply hooks over locating pins (supplied) so it can be fitted or removed in seconds.

Model No. 13145

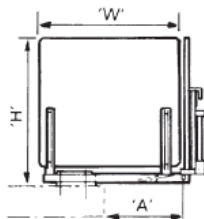

End elevation showing guard in maximum forward position.
A=2'(min.) up to 11' (max.)

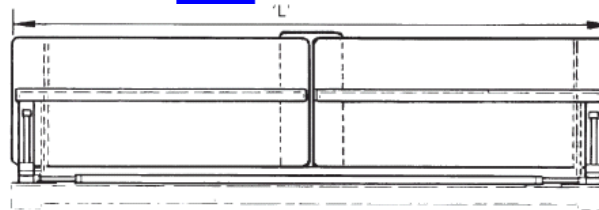

Front view with sliding guards closed

MODEL NO.	FOR TABLE LENGTH	SIDE PANEL HEIGHT	SIDE PANEL WIDTH	FRONT PANEL HEIGHT
*13088-H	32"-44"	23 5/8"	19 1/2"	23 5/8"
**13089-H	44"-56"	23 5/8"	19 1/2"	23 5/8"
**13090-H	56"-76"	23 5/8"	19 1/2"	23 5/8"

*Has ONE Sliding front door and one hinged front panel.

**Has TWO Sliding front doors of equal size.

Safety is our Specialty!



General Safety Company LTD.

Industrial Machines Safety: Components and Solutions

2175 Sheppard Ave. East Unit 250, Toronto, Ontario, M2J 1W8
Tel. (416) 645-0242 Fax. (416) 447-0091

VISORGUARD

Provides Complete Protection between Cutting Tool and Operator's Eyes



In use: Visiogard Down

DOWN-TO-EARTH FEATURES!

1. Flexbar arm permits setting of Visorguard at the correct height and angle for each setup.
2. Flip shield up to load part and down for machining.
3. Special spring-loaded shaft makes shield stay put - no springback.
4. Wing-shaped shield protects workers at adjacent machines.
5. Flexbar locks rigid; has stainless air-craft-grade tension cable.
6. Can be installed in minutes on CNC mills, conventional milling machines and others.

DIMENSIONS:

- Shield Size - 16" wide x 8" high
- Flexbar Arm - 10" long

Model No. 13055 - Visorguard

Complete with mounting bracket, Flexbar and all hardware including mounting hole and thumbscrew for attaching coolant system.

Model No. 13054

Replacement Shield, 16" wide x 8" high

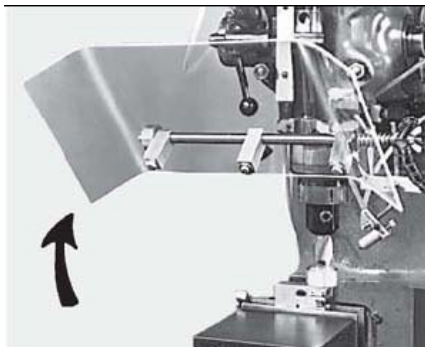

Flip up to change work-piece or tool . . . no loss in productivity!



LONG REACH VISORGUARD

Provides Complete Protection Between Cutting Tool and Operator's Eyes For Large Milling Machines (vertical and horizontal) and Unguarded Machines.

Model No. 13050, Long Reach Visorguard™

Complete with hardware, tube and mounting bracket.

Replacement Lexan Shield for Long Reach Visorguard:

Model No. 13054

Replacement Cable for Visorguard:

Ball & Thread Cable for all Visorguard Models Model No. 80063-6

OPTIONAL SIZES OF VISORGUARD SHIELDS NOW AVAILABLE: See bottom of next page.

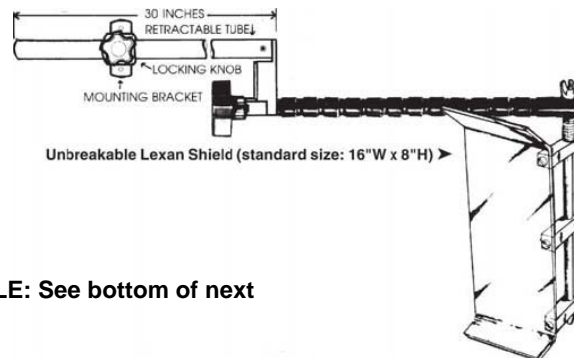

Safety is our Specialty!



General Safety Company LTD.

Industrial Machines Safety: Components and Solutions

2175 Sheppard Ave. East Unit 250, Toronto, Ontario, M2J 1W8
Tel. (416) 645-0242 Fax. (416) 447-0091

VISORGUARD UNIVERSAL

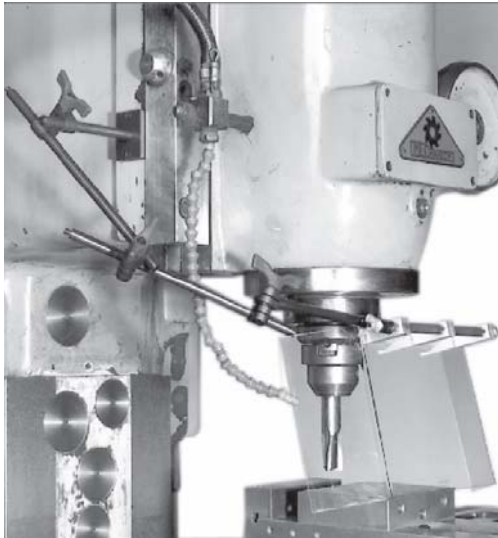

**Fully Adjustable Long Reach Guard (Lexan®)
For Milling Machines and Unguarded
Machines Multi-spindles, Bandsaws, etc.**



Unique universal positioning design is fully adjustable. Visorguard shield is mounted and supported by a series of heavy duty arms and swivel clamps thus allowing the operator to "custom fit" each guard as to overall length, angle and position of shield. Wing-shaped Visorguard shield protects workers at adjacent machines.

LONG REACH FROM HEADSTOCK MOUNTING PLATE/POST IS ADJUSTABLE TO 36"

Visorguard Universal consists of:

- Mounting plate with 4" x 1/2" post — just drill and tap into headstock ... supplied with four cap screws
- 2 each 15" x 1/2" arms (24" arms available upon request - phone or fax).
- 3 each 1/2" x 1/2" heavy duty swivel clamps with extra-large wing style locking knob
- 16" x 8" high Lexan® Visorguard shield assembly with 6" attachment post & coupling

Ordering:

Model No. 13047, Visorguard Universal

Model No. 13048, Extra-Wide Visorguard Universal — same as 13047 but with 24" wide x 8" high Lexan® shield (3/16" thick) for larger machines such as multi -spindles

Model No. 13054, 16" x 8" Replacement Shield

Model No. 13046, 24" x 8" Replacement Shield

Other size shields available for Visorguard Universal:

EXTRA-LONG VISORGUARD SHIELDS ONLY		
Model No.	Width	Height
<u>13046</u>	24"	8"
<u>13073</u>	14 1/2"	12"
<u>13074</u>	15"	16"

Safety is our Specialty!



General Safety Company LTD.

Industrial Machines Safety: Components and Solutions

2175 Sheppard Ave. East Unit 250, Toronto, Ontario, M2J 1W8
Tel. (416) 645-0242 Fax. (416) 447-0091

MILLING MACHINE VISORGUARD KIT

Provides Complete Protection Between Cutting Tool and Operator's Eyes



Down-To-Earth Features!

- Easy Grab Handle
- Flexbar Arm permits setting of Visorguard at the correct height and angle for each setup
- Mounts on most machines, even with digital readouts, in minutes
- All mounting brackets included
- Shield size 16" wide x 8" high

Model No. 13460, Milling Machine Visorguard Kit

Model No. 13054, Replacement Shield

Model No. 13461, Extra Long 24" Vertical Angle

Model No. 80063-1138, Replacement Flexarm Cable

DRILL PRESS VISORGUARD KIT

Provides Operator Protection from Chips and Broken Drills on Drill Presses and Drilling Equipment

Features:

- Easy Grab Handle
- Flexbar Arm permits setting of Visorguard at the correct height and angle for each setup
- Mounts on most machines in minutes
- All mounting brackets included
- Shield Size 6" wide x 6" high with 4" sides

Model No. 13462, Drill Press Visorguard Kit

Model No. 13033, Replacement Shield

Model No. 13461, Extra Long 24" Vertical Angle

Model No. 13463, Extra Long 28" Horizontal Tube

Model No. 80063-1138, Replacement Flexarm Cable

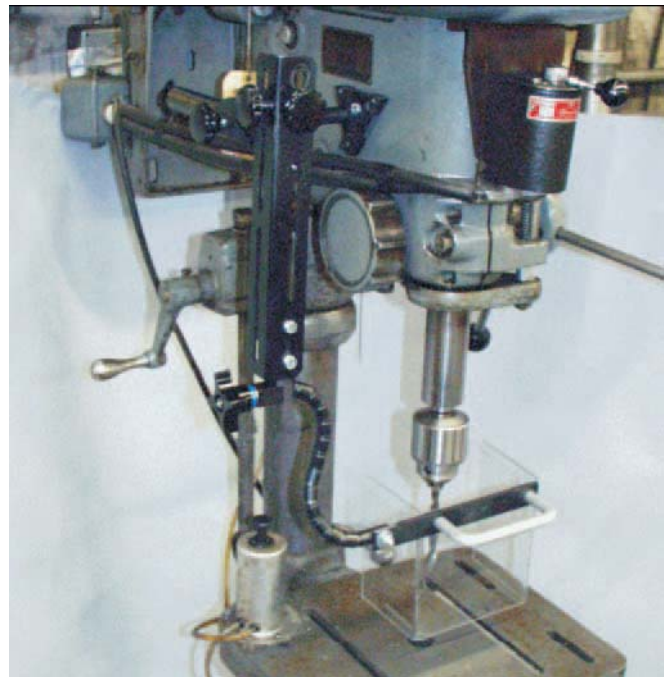

Safety is our Specialty!



General Safety Company LTD.

Industrial Machines Safety: Components and Solutions

2175 Sheppard Ave. East Unit 250, Toronto, Ontario, M2J 1W8
Tel. (416) 645-0242 Fax. (416) 447-0091

DRILL/CHUCK VISORGUARD

Standard Mount and New Long Reach Mount

Provides Operator Protection From Chips And Broken Drills On Drill Presses, Milling Machines And Other Drilling Equipment.

Similar features to Flexbar Visorguard Model No. 13055

SAFETY FEATURES INCLUDE:

1. Flexbar arm permits setting of guard at the correct height and angle for each setup.
2. Flip shield up to load part and down for drilling.
3. Special spring-loaded shaft makes shield stay put - no springback.
4. Wing-shaped shield (90° angled) protects workers at adjacent machines.
5. Flexbar locks rigid; has stainless aircraft-grade tension cable.
6. Can be installed in minutes on drill presses, mills, milling machines and others.

DIMENSIONS:

- Shield Size - 6" wide x 6" high
- Flexbar Arm - 10" long

Model No. 13032, Drill/Chuck Visorguard

Complete with mounting bracket, Flexbar arm and all hardware including mounting hole and thumbscrew for attaching coolant system.

Model No. 13032-L, Long Reach Drill/Chuck Visorguard.

Same Mount as Model No. 13050. See Page 12.

Model No. 13033, Replacement Shield

Replacement Cable for Visorguard:

Model No. 80063-6, Ball & Thread Cable for Visorguard



The VISEGUARD

Quick and easy vise mount Lexan® shield helps to protect machine operators from hot chips and coolant spray at the spindle of your machine

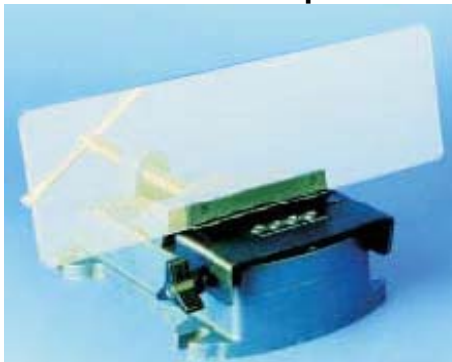

Shield dimensions (both Models): 25" x 5" x 17"

Advantages:

- Easy to use - the Viseguard fits over the end of most standard vises
- Clamps on in seconds
- Flexible - when access to the workpiece is needed, the shield flips down easily (using heavy-duty hinge)
- Deflects chips - chips are deflected down and away from the machine operator
- See-through - allows the operator to view the work-piece while the machining is being performed
- Easy mounting - clamps in place with the twist of a knob
- Shatter resistant - made of high strength polycarbonate

Model No. 13147, for use on standard 6" vise systems

Model No. 13148, for use on standard 8" vise systems

Safety is our Specialty!



General Safety Company LTD.

Industrial Machines Safety: Components and Solutions

2175 Sheppard Ave. East Unit 250, Toronto, Ontario, M2J 1W8
Tel. (416) 645-0242 Fax. (416) 447-0091

BAND SAW VISORGUARD

Provides Complete Protection Between Cutting Blade and Operator's Hands and Eyes.



Features Include:

- L" Shaped Lexan Shield, 6" H x 6" W x 4" D
- Easy Position Handle
- Adjustable Tension 9" Long Flexbar Arm Permits Correct Setting of Guard for Each Setup
- Includes Vertical Angle Mounting Bracket with 11" of Height Adjustment
- Kit Includes Mounting Screws and Self Locking Nuts. Simply Drill and Tap 2 Holes and Install

Installs on most band saws with 18" maximum throat height.

Optional extra-long vertical angle bracket assembly available for larger throat height machines. Phone or fax for details.

Ordering:

Model No. 13464 Band Saw Visorguard Kit

Complete with mounting bracket, Flexbar Arm, shield and all hardware

Model No. 13465 Replacement Shield with Handle

Model No. 80063-6 Replacement Flexbar Arm Cable

SCROLL SAW VISORGUARD KIT

Provides Complete Protection Between Saw Blade and Operator's Eyes

Features Include:

- Easy Grab Handle
- Flexbar Arm permits setting of Visorguard at the correct height and angle for each setup
- Mounts on most machines in minutes
- All mounting brackets included
- Shield size 6" wide X 8" high

Scroll Saw Visorguard Kit.....**Model No. 13466**

Replacement Shield.....**Model No. 13467**

Replacement Flexarm Cable....**Model No. 80063-1138**



Safety is our Specialty!



General Safety Company LTD.

Industrial Machines Safety: Components and Solutions

2175 Sheppard Ave. East Unit 250, Toronto, Ontario, M2J 1W8
 Tel. (416) 645-0242 Fax. (416) 447-0091

TELESCOPIC DRILLGUARD

Provides Complete Operator Protection!

Interchangeable bushings available to accommodate most drill press quill sizes.

FEATURES:

- Complete operator vision and protection assured.
 - Smooth telescopic action via patented spiral guide grooves-window caged housing moves up while drill comes down; hence cutting tool is totally guarded.
 - For drill changes - simply pull down on housing. Three spring loaded ball catches disengage and the housing drops out. Conversely, it quickly snaps back in place.
 - Inner cage moving down protects window hence the operator from metal slivers.
- Quality made of heavy duty material, Telescopic Drillguard comes complete with installation and operation instruction. The Quill Ring (which holds cage housing) is made of heavy die-cast aluminum, with smooth finish.

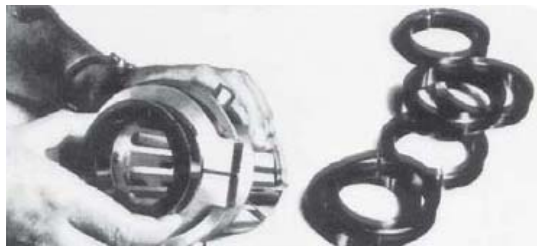
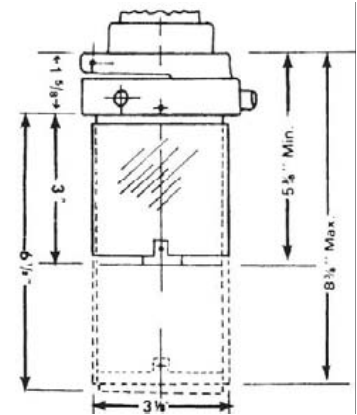

Order No.	Description	Fits Quill Dia. (inches)	
		Up to	from
13125	Drillguard	2.75"	2.626"
13127	Bushing	2.625"	2.563"
13128	Bushing	2.562"	2.501"
13129	Bushing	2.500"	2.438"
13130	Bushing	2.437"	2.376"
13131	Bushing	2.375"	2.313"
13132	Bushing	2.312"	2.251"
13133	Bushing	2.250"	2.188"
13134	Bushing	2.187"	2.126"
13135	Bushing	2.125"	2.063"
13136	Bushing	2.062"	2.000"
	(or Metric Equivalent)		
13126	Acrylic	(Fits All)	
Replacement Windows			
While maximum diameter shown is 2 3/4", the mounting collar can be chucked and bored out to 2 7/8" diameter or slightly more.			

Safety is our Specialty!



General Safety Company LTD.

Industrial Machines Safety: Components and Solutions

2175 Sheppard Ave. East Unit 250, Toronto, Ontario, M2J 1W8
Tel. (416) 645-0242 Fax. (416) 447-0091

THE LEXAN VERSA-SHIELD

Protects Your Eyes Against Chip & Liquid Burns



The new, patent pending, tough 1/8" thick polycarbonate Versa-Shield offers clarity from its front or from its side plus resistance to impact, hot chips, oil, grease and splashing coolants. The uniquely curved shape directs chips away from the user and helps recycle coolants. The shield measures 12" wide by 11" high and is ideal for bench grinders, buffers, lathers, planers, spot welders and more. Versa-Shield is available on a rugged, flexible gooseneck arm or on a Flexbar

Universal Positioning Arm with Quick Cam Action Locking. The Flexbar Universal Positioning Arm locks the shield positively where placed. A variety of mounting options are offered below:



I. Flexible Gooseneck Arm Models (on 3.16" diameter disc type magnetic base):

Model No. 13448, Versa-Shield on 12" long gooseneck arm

Model No. 13449, Versa-Shield on 24" long gooseneck arm



II. Flexbar Universal Positioning Arm Models (Flexarm is 14" long)

Model No. 13450, Versa-Shield on Flexbar with 3.16" diameter disc magnet

Model No. 13451, Versa-Shield on Flexbar with c-clamp. Clamp capacity 1 3/8" throat to center of screw

Model No. 13452, Versa-Shield on Flexbar heavy duty 6" diameter weighted base

Model No. 13453, Versa-Shield on Flexbar with No. 7 CR Vise Grip

13450



13452



13451



13453

Replacement Shield **Model No. 13455** 12" wide x 11" high. Fits all mounting options

Safety is our Specialty!



General Safety Company LTD.

Industrial Machines Safety: Components and Solutions

2175 Sheppard Ave. East Unit 250, Toronto, Ontario, M2J 1W8
Tel. (416) 645-0242 Fax. (416) 447-0091

The LEXAN® FLEX-SHIELD

Protects Your Eyes Against Chip & Liquid Burns.

Safety Shield on Flexbar Universal Positioning Arm. Quick Cam Action Locking
(Shield swivels 360° and locks positively where placed).

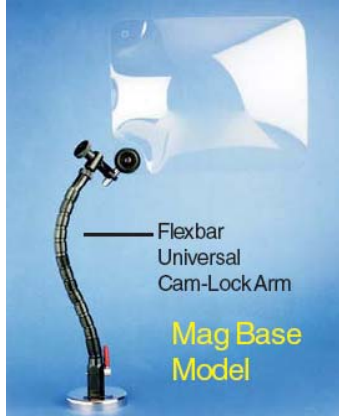

Now Available in Mag Base, "C" Clamp and Base Mount Models.

- Overall height of Flexbar Stand: 14"
- Super Power Disc Mag Base: 3.16" dia.
- C-Clamp Capacity: 1 3/8", Throat to center of screw 11/16"
- Base Mount for permanent mounting on machine
- Shields made of durable clear view Lexan - 1/8" thick
- Choice of concave or flat

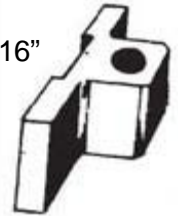

C-Clamp Mount



Base Mount

CONCAVE SHIELD MODELS-Complete			
Shield Size	Mag Base Model	C-Clamp Model	Base Mount Model
6" x 8"	13313	13313-C	13313-B
8" x 10"	13314	13314-C	13314-B
10" x 12"	13315	13315-C	13315-B

FLAT SHIELD MODELS-Complete			
Shield Size	Mag Base Model	C-Clamp Model	Base Mount Model
6" x 8"	13316	13316-C	13316-B
8" x 10"	13317	13317-C	13317-B
10" x 12"	13318	13318-C	13318-B

LEXAN® REPLACEMENT SHIELDS - Carton of 3			
CONCAVE		FLAT	
<u>13093-L</u>	6" x 8"	<u>13120-L</u>	6" x 8"
<u>13094-L</u>	8" x 10"	<u>13121-L</u>	8" x 10"
<u>13095-L</u>	10" x 12"	<u>13122-L</u>	10" x 12"

CHIPGUARD DEFLECTORS

with Polycarbonate Shields Made of Lexan® (3/16" thick)



- Swivel Base Positioner affords incredible variety of shield positioning instantly. Shield swivels 360 degrees in two planes and 180 degrees in 3rd plane. A small twist on locking knob positively locks all.
- Cantilever Design - leaves room for shield to cover work area.

Model N o.	On Magnetic Base		
	A	B	C
13010	4"	6"	2 5/8" dia .
13011	6"	8"	2 5/8" d ia .
13012	8"	12"	2 5/8" d ia .

Safety is our Specialty!



General Safety Company LTD.

Industrial Machines Safety: Components and Solutions

2175 Sheppard Ave. East Unit 250, Toronto, Ontario, M2J 1W8
 Tel. (416) 645-0242 Fax. (416) 447-0091



EYEGUARD

Protects Your Eyes Against Chip Burns

Now Available in Lexan®

Safety Shield on Universal Positioning Magnetic Stand with On/Off Lever

- Overall Height of Stand:
 - Base to top of post is 10" long
 - Extension rod — 7" long
- Magnetic base is powerful
- Shields made of durable clear
- view plastic 1/8" thick - choice of
- acrylic or Lexan® models.
- Concave and flat shields
- interchangeable on all models
- (Eyeguard and Splashguard)

CONCAVE SHIELD MODELS (ACRYLIC)		FLAT SHIELD MODELS (ACRYLIC)	
MODEL NO.	SHIELD SIZE	MODEL NO.	SHIELD SIZE
13098	6" x 8"	13103	6" x 8"
13099	8" x 10"	13104	8" x 10"
13100	10" x 12"	13105	10" x 12"
13101	12" x 16"	13106	12" x 16"
13102	16" x 20"	13107	16" x 20"
LEXAN® SHIELD EYEGUARD MODELS			
13098-L	6" x 8"	13103-L	6" x 8"
13099-L	8" x 10"	13104-L	8" x 10"
13100-L	10" x 12"	13105-L	10" x 12"
13101-L	12" x 16"	13106-L	12" x 16"
13102-L	16" x 20"	13107-L	16" x 20"
CONCAVE REPLACEMENT SHIELDS (ACRYLIC) CARTON OF 3		FLAT REPLACEMENT SHIELDS (ACRYLIC) CARTON OF 3	
MODEL NO.	SHIELD SIZE	MODEL NO.	SHIELD SIZE
13093	6" x 8"	13120	6" x 8"
13094	8" x 10"	13121	8" x 10"
13095	10" x 12"	13122	10" x 12"
13096	12" x 16"	13123	12" x 16"
13097	16" x 20"	13124	16" x 20"
LEXAN® REPLACEMENT SHIELD			
13093-L	6" x 8"	13120-L	6" x 8"
13094-L	8" x 10"	13121-L	8" x 10"
13095-L	10" x 12"	13122-L	10" x 12"
13096-L	12" x 16"	13123-L	12" x 16"
13097-L	16" x 20"	13124-L	16" x 20"
Model No. 13092 Eyeguard Magnetic On/Off Stand Only			

Safety is our Specialty!



General Safety Company LTD.

Industrial Machines Safety: Components and Solutions

2175 Sheppard Ave. East Unit 250, Toronto, Ontario, M2J 1W8
Tel. (416) 645-0242 Fax. (416) 447-0091

SPLASHGUARD

"State Of The Art Protection" Now Available in Lexan®



Protects Your Eyes Against Chip & Liquid Burns. Safety Shield on Tilt-type Magnetic Stand (Shield swivels 360o and locks positively where placed).

- Overall Height of Stand: 9 inches (Base to top of post)
- Powerful Magnetic Base
- Shields made of durable clear view plastic - 1/8" thick - choice of acrylic or Lexan® models
- Concave and flat shields are interchangeable on all models
- Splashguard and Eyeguard.

POWERFUL MAGNETIC BASE

- 10 MODELS WITH CONCAVE SHIELD
- 10 MODELS WITH FLAT SHIELD

SPLASHGUARD SWIVELBALL MAGNETIC STAND COMPLETE WITH CONCAVE SHIELD

SPLASHGUARD SWIVELBALL MAGNETIC STAND COMPLETE WITH FLAT SHIELD

MODEL NO.	SHIELD SIZE	MODEL NO.	SHIELD SIZE
<u>13108</u>	6" x 8"	<u>13115</u>	6" x 8"
<u>13109</u>	8" x 10"	<u>13116</u>	8" x 10"
<u>13110</u>	10" x 12"	<u>13117</u>	10" x 12"
<u>13111</u>	12" x 16"	<u>13118</u>	12" x 16"
<u>13112</u>	16" x 20"	<u>13119</u>	16" x 20"
LEXAN® SHIELD SPLASHGUARD MODELS			
<u>13108-L</u>	6" x 8"	<u>13115-L</u>	6" x 8"
<u>13109-L</u>	8" x 10"	<u>13116-L</u>	8" x 10"
<u>13110-L</u>	10" x 12"	<u>13117-L</u>	10" x 12"
<u>13111-L</u>	12" x 16"	<u>13118-L</u>	12" x 16"
<u>13112-L</u>	16" x 20"	<u>13119-L</u>	16" x 20"
Model No. <u>13091</u> Splashguard Magnetic Stand Only			
CONCAVE AND FLAT REPLACEMENT SHIELDS AVAILABLE- SEE BOTTOM OF PAGE 20			

Safety is our Specialty!



General Safety Company LTD.

Industrial Machines Safety: Components and Solutions

2175 Sheppard Ave. East Unit 250, Toronto, Ontario, M2J 1W8
Tel. (416) 645-0242 Fax. (416) 447-0091



FLEXIGUARD

Curved Plastic Shields On Rugged Flexible Goosenecks

- Positively deflects chips and coolant.
- Permits clear & closer visual inspection of work.

2 MODELS AVAILABLE

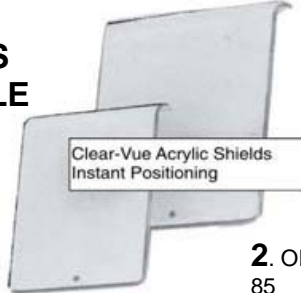

1. ON C-CLAMP: Permits clamping of safety shield on hard-to-affix locations whether flat, round, etc.
1. Made of malleable iron with 120° vee. Clamp capacity - 1 3/8". Throat to center of screw - 1 1/16".
1. Length of flex arm with C-Clamp - 13 1/2".

MODEL NO.	SHIELD SIZE
<u>13001</u>	7 1/2" x 10"
<u>13002</u>	10" x 12"
<u>13003</u>	12" x 16"

2. ON MAGNETIC BASE: Disc-type magnet - 85 lbs. pull. Length of flex arm with magnet - 10".
1. Shield swivels and locks 360°.

MODEL NO.	SHIELD SIZE	SIZE OF MAGNET
<u>13004</u>	7 1/2" X 10"	2.65" diameter
<u>13005</u>	10" X 12"	2.65" diameter
<u>13006</u>	12" X 16"	3.16" diameter

REPLACEMENT SHIELDS

MODEL NO.	SIZE
<u>13007</u>	CTN. OF 3 7 1/2" x 10"
<u>13008</u>	CTN. OF 3 10" x 12"
<u>13009</u>	CTN. OF 3 12" x 16"
<u>13140</u>	1 SHIELD 7 1/2" x 10"
<u>13141</u>	1 SHIELD 10" x 12"
<u>13142</u>	1 SHIELD 12" x 16"

REPLACEMENT PARTS (SHIELD NOT INCLUDED)

	NO.
FLEXIGUARD ARM ON C-CLAMP	<u>13137</u>
FLEXIGUARD ARM ON 2.65" DIA. MAGNET	<u>13138</u>
FLEXIGUARD ARM ON 3.16" DIA. MAGNET	<u>13139</u>

HELICAL METAL Leadscrew COVERS

Flexbar covers are the perfect shield for meeting safety requirements on Hydraulic Rods, Lead Screws and Die Posts by eliminating pinch points. These simple helical metal coils surround and protect sensitive cylindrical mechanisms with overlapping coils that seal out dirt, chips, and contaminants. The spring action memory holds the unit in place as it expands and compresses between two parallel surfaces. So efficient are FLEXBAR COVERS, especially in harsh environments, that most users report they outlast bellows types by as much as 20 to 1! This results in reduced capital equipment replacement costs, as well as in added productivity through the elimination of more frequent installation associated with less durable shielding devices.



Now Also Available: **OPEN WOUND METAL LEADSCREW COVERS**

No need to disassemble equipment, just wind on cover and install split pilot and retainer.

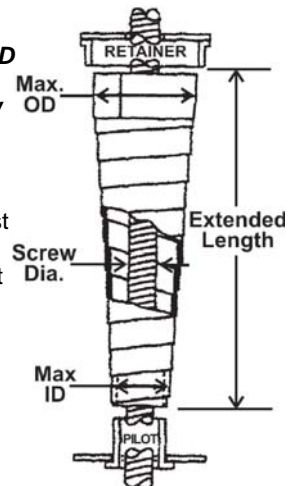

Safety is our Specialty!



General Safety Company LTD.

Industrial Machines Safety: Components and Solutions

2175 Sheppard Ave. East Unit 250, Toronto, Ontario, M2J 1W8
Tel. (416) 645-0242 Fax. (416) 447-0091

PIVOT MOUNT GRINDER GUARD AND UNIVERSAL SHIELD



Heavy-duty swivel-lock positioning shield protects operator from flying grit and debris. Cast frame with virtually unbreakable 3/16" thick Lexan® shield will contain and deflect any wheel breakage.

One standard frame with a choice of three sizes of interchangeable Lexan® shields will provide protection for grinding and buffing wheels up to 14". An extra heavy-duty steel pivot with locking knob connects the frame to the curved adjustable mounting bracket.

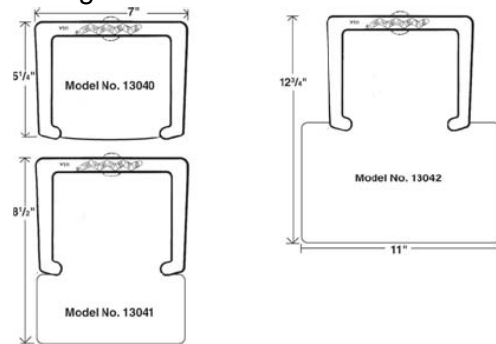

Each model supplied complete with frame, Lexan® shield and pivot mount hardware. Replacement shields available (see chart).

Model No.	For Bench Grinders	Shield Size
<u>13040</u>	6", 7", 8"	5 1/2" x 5 3/4"
<u>13041</u>	8", 10"	6 1/2" x 8 1/2"
<u>13042</u>	10" and up	12 3/4" x 11"
<u>13043</u>	Lexan® Replacement shield for <u>13040</u>	
<u>13044</u>	Lexan® Replacement shield for <u>13041</u>	
<u>13045</u>	Lexan® Replacement shield for <u>13042</u>	

GRINDER GUARD

Designed to fit virtually all pedestal and bench grinders

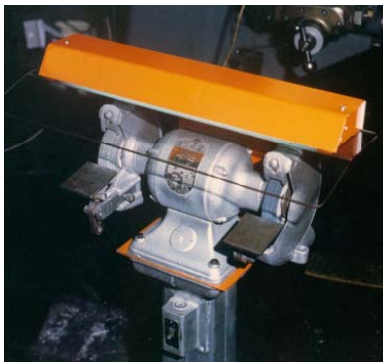

- Full Width Protection.
- **Built-in Fluorescent Light.**
- 27" Lexan Impact-Resistant Visor.
- Heavy Gauge Steel Construction.
- Permanent Mounting, Bolts To Any Grinder (Bench or Pedestal).
- OSHA Orange.

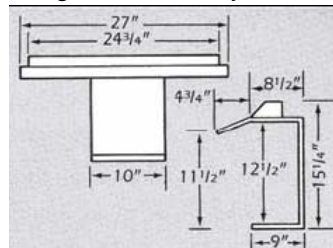

Model No. 13019,
Model No. 13020
dimensions are same,
except depth is 14 1/2" and
overall height is 19".

Two Models Available:

Model No. 13019, Grinder Guard fits grinders with up to 8" wheels (7" wheels on Baldor grinders)

Model No. 13020, Grinder Guard fits grinders with 8" to 12" wheels

Model No. 13021, Lexan replacement shield 27" x 9 1/2" (For models 13019 and 13020)

Safety is our Specialty!



General Safety Company LTD.

Industrial Machines Safety: Components and Solutions

2175 Sheppard Ave. East Unit 250, Toronto, Ontario, M2J 1W8
Tel. (416) 645-0242 Fax. (416) 447-0091

OTHER AVAILABLE GUARDING PRODUCTS

Belt/Disc Sander Guards

Protects User from Unused Portion of Belt/Disc

- Easily Adjustable
- Upper & Lower Guards Available

Model No. 13382, Upper Belt Sander Guard

Model No. 13383, Lower Belt Sander Guard

Model No. 13384, 12" Disc Sander Guard

Model No. 13385, 16" Disc Sander Guard



Spindle Sander Guards

Upper and Lower Guards Available

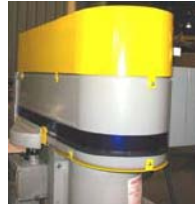

Model No. 13386, 6" x 11" Floor Mount Spindle Sander Guard

Model No. 13387, 6" x 11" Base Mount Spindle Sander Guard

Model No. 13388, 6" x 11" Bench Mount Spindle Sander Guard

Model No. 13389, 4" x 7" Bench Mount Spindle Sander Guard

Model No. 13378, Top Cover Guard

Model No. 13379, Lower Motor Guard



Drill Press Belt/Pulley Guard

Many styles Available for Top Covers & Lower Motor Guards

FLEXBAR GRINDER GUARD DELUXE

Heavy-Duty Lexan® Shield (3/16" thick) Guards Against Wheel Explosions!

Designed to fit virtually all pedestal and bench grinders as well as buffers and speed lathes.

Fits Grinder/Buffer wheel diameter from 6" to 14"

ALL UNITS INCLUDE:

- A) 2 Curved Shield Assemblies
- B) Vertical Post Assembled With 2 Mounting Brackets
- C) 2 Each, 1 inch wide standoffs with hex head bolts and washers
- D) 1 Vertical Mounting Bracket

*On Single Shield Models:

- A) 1 Each Curved Shield
- B) Vertical Post Has One Mounting Bracket
- C) Same as above
- D) Same as above

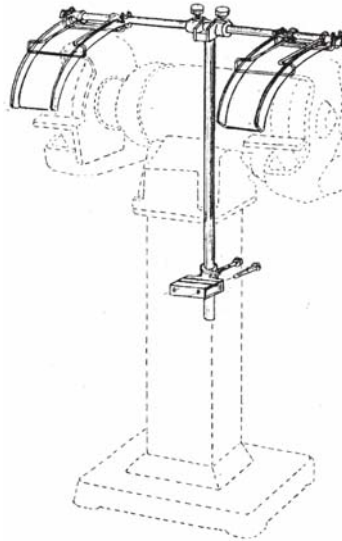

Shown Above: Pedestal Mount Grinder Guard Deluxe with adjustable mounting hardware.

PEDESTAL MOUNT MODELS- ORDERING:

GRINDER/BUFFER WHEEL DIAMETER	WITH SINGLE SHIELD* MODEL NO.	WITH DOUBLE SHIELDS MODEL NO.
6" or 7"	13390-S	13390-D
8"	13391-S	13391-D
10" & 12"	13392-S	13392-D
14"	13393-S	13393-D

* Please specify "Left Mount" or "Right Mount" on Single-Shield Models.
Single Shield Models are listed for Single-Wheel Buffers, etc., which are in existence.

Safety is our Specialty!



General Safety Company LTD.

Industrial Machines Safety: Components and Solutions

2175 Sheppard Ave. East Unit 250, Toronto, Ontario, M2J 1W8
Tel. (416) 645-0242 Fax. (416) 447-0091

MOTOR CONTROLS

With One Easy-to-Install unit you can provide:

- Standardized machine controls
- Power Outage protection
- E-Stop actuator with mushroom shape
- Built with only the finest solid-state components
- No contacts to burn out - fail-safe design
- Just 3" x 3.75" x 6.25"



Motor Control 120 Volt.....**Model No. 13380**

Motor Control High Voltage.....**Model No. 13381**

(This control requires installation by a qualified electrician)



Easy to Install:

1. Mount the 13380 on your machine.
2. Plug the machine into the 13380.
3. Plug the 13380 into your outlet.

SAFETY MARKING TAPE

Solid and Striped Vinyl Marking Tape
Highly Versatile...Extremely Economical

Easy-to-use self-adhesive vinyl tapes are ideal for a variety of uses including safety marking machinery, aisle marking, pipe wrapping, duct sealing, packaging and marking dangerous areas. Resists oil, dirt, and chemicals. Abrasion resistant and highly visible for increased safety. Complies with OSHA color requirements.



Model No. 13520, Solid Yellow 2" wide x 36 yards

Model No. 13521, Yellow/Black Striped 2" wide x 18 yards

Model No. 13522, Solid Yellow Dot 3" Diameter-500 per roll

SOLID AND STRIPED ANTI-SLIP/NON-SKID VINYL TAPE

Easy-to-use self-adhesive vinyl tape with safety grit surface is ideal for flooring, Industrial areas, machine areas, loading ramps and stair threads. It can be used in wet or dry applications and is available in a variety of sizes.



Model No. 13525, Solid Yellow 2" x 60 Ft.

Model No. 13526, Solid Yellow 6" x 60 Ft.

Model No. 13527, Solid Yellow 12" x 60 Ft.

Model No. 13528, Yellow/Black Striped 2" x 60 Ft.

Model No. 13529, Yellow/Black Striped 6" x 60 Ft.

Model No. 13530, Yellow/Black Striped 12" x 60 Ft.

Safety is our Specialty!



General Safety Company LTD.

Industrial Machines Safety: Components and Solutions

2175 Sheppard Ave. East Unit 250, Toronto, Ontario, M2J 1W8
Tel. (416) 645-0242 Fax. (416) 447-0091

PANELGUARD

Flexible, Modular Machine Guarding System

The PANELGUARD Movable, Multiple Function Machine Guard's 4 panel system provides complete flexibility and can be used for a variety of applications, which include:

- Creating Machine Safety Areas.
- Perimeter Guarding.
- Temporary Guarding.
- Machines having large parts or cutting tools.
- Reducing machine noise.
- Blocking off out of service machines or areas undergoing maintenance.



**Model No. 13035
Basic 4-Panel System**



Shown above: Panelguards used to separate in-line machines. Protects operators from chips and noise from neighboring machines.

The **PANELGUARD** system has four modular panels 16"W x 71"H and opens 66" across. Its simple construction conforms to fit different configurations. The upper half of each panel has crystal clear high impact resistant Lexan, which gives operator protection and a full view of guarded machines or areas. The **PANELGUARD** may be used free-standing or can be more permanently affixed to the shop floor using Adhaesium® strips. (Phone or fax for information and availability).

Safety is our Specialty!



General Safety Company LTD.

Industrial Machines Safety: Components and Solutions

2175 Sheppard Ave. East Unit 250, Toronto, Ontario, M2J 1W8
Tel. (416) 645-0242 Fax. (416) 447-0091

PANELGUARD

CREATE A CUSTOM MACHINE GUARDING SYSTEM OR SAFETY AREA BY ADDING MODULAR EXPANSION PANELS.

APPLICATION: ▶

Temporarily enclose equipment using 1 or more Flexbar PanelGuards during maintenance, repair or to comply with lockout - tagout situations.

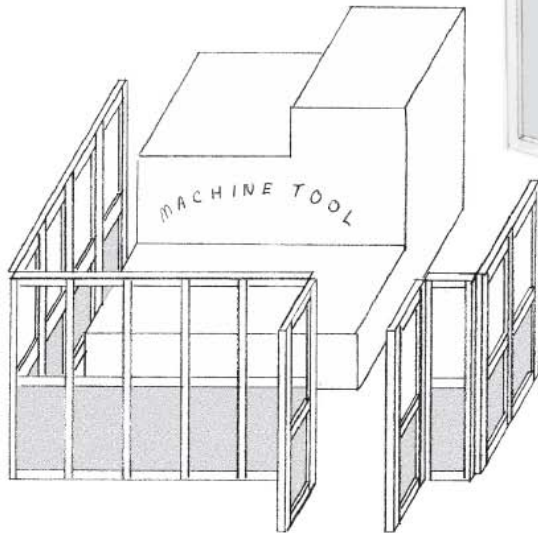
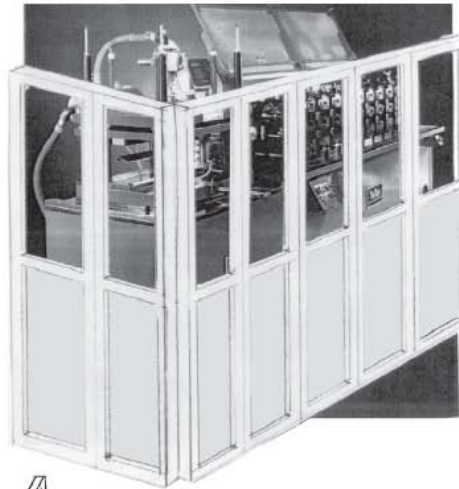

APPLICATION:

Create a machine tool enclosure by connecting Flexbar PanelGuards together leaving 2 panels as access doors. Doors can be fitted with optional user supplied interlocks.

*ORDERING:

*Model No. 13035, PANELGUARD Basic 4-Panel Set Complete

*Model No. 13036, PANELGUARD 2-Panel Expansion Set
Complete with extra slide-in flexible hinge

*Model No. 13037, Extra slide-in flexible hinge (1 ea.)

*Model No. 13038, Top Cap (1 ea. per panel)
Used to connect two or more Panelguard sets together.

Safety is our Specialty!



General Safety Company LTD.

Industrial Machines Safety: Components and Solutions

2175 Sheppard Ave. East Unit 250, Toronto, Ontario, M2J 1W8
Tel. (416) 645-0242 Fax. (416) 447-0091

Table Saw Guard

Combines the productivity of a stock pusher with the safety of a saw blade guard!



Special Features:

- Adds safety by removing the operator's hands from the saw blade area.
- Adds productivity by eliminating the use of stock pusher sticks and gadgets, which are frequently missing.
- Accommodates all wood ripping and some cross-cutting applications.
- Spring return system always keeps the guard in ready position.

Easy to install

- All mounting brackets are included.
- Fits most 10" table saws. Including Powermatic, Delta, Jet, Skil, Dewalt and Craftsman.
- Standard OEM saw blade guard and stock splitter must be installed and functioning on the saw to use the Table Saw Guard properly.
- Can also be used with many after market Saw blade guards.
- See illustration on opposite page for complete size mounting application.



Table Saw guard guiding stock through the blade

Safety is our Specialty!



General Safety Company LTD.

Industrial Machines Safety: Components and Solutions

2175 Sheppard Ave. East Unit 250, Toronto, Ontario, M2J 1W8
Tel. (416) 645-0242 Fax. (416) 447-0091

Table Saw Guard

INCREASE PRODUCTIVITY

The **SAW GUARD** Table Saw Guard increases productivity by being a stock pusher that is permanently mounted on the table saw and it has adjustable push arms for different width stock. Unlike push sticks and temporary stock pushers, which are difficult to use and easily misplaced the **SAW GUARD** is always ready. For crosscutting stock the **SAWGUARD** may be locked at the back of the table saw and out of the way.

INCREASE SAFETY

The **SAW GUARD** Table Saw Guard increases safety by allowing the operator to cut stock without ever placing his hands or fingers near the saw blade.

The **SAW GUARD's** handle design put operator's hands high above the saw blade and the **LEXAN** shield provides a clear view safety partition between operator and saw blade.



Feeding Stock Under Saw Guard

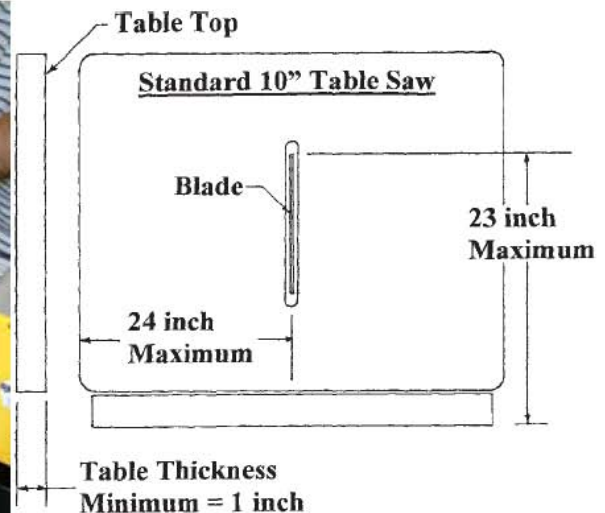

Model No. 13470, Saw Guard Table Saw Guard includes Stock Pusher/Guard Unit, 2 standard Push Arms and Mounting Angles.

Model No. 13471, Replacement Lexan Shield

Model No. 13472, Replacement Push Arm.

Model No. 13473, Thin Push Arm: Allows ripping width as narrow as 3/16"

Model No. 13474, Saw Guard Mounting Extension. Positions Saw Guard 24" from blade on any table saw allowing cuts up to 24".

Safety is our Specialty!



General Safety Company LTD.

Industrial Machines Safety: Components and Solutions

2175 Sheppard Ave. East Unit 250, Toronto, Ontario, M2J 1W8
Tel. (416) 645-0242 Fax. (416) 447-0091

SENSING-SAF-START

The Inexpensive Solution to OSHA. Anti-automatic Restart Protection Without the High Cost of Magnetic Motor Starters

THIS IS A MANDATORY OSHA SAFETY REQUIREMENT

OPERATING CHARACTERISTICS

With the Sensing-Saf-Start® correctly installed on existing equipment, it will provide protection against unexpected start-up, motion, and motor burn-out in the following manner:

VOLTAGE DROP OR POWER INTERRUPTION PROTECTION -

In the event equipment, while being operated (switch in the "ON" position), should stop due to loss or drop of electrical power due to POWER FAILURE from any cause, the Sensing-Saf-Start® will automatically disconnect and shut off power to the equipment, so that upon restoration of power, the equipment will not start up even though the power switch to the equipment is in the "ON" position. In order to restore power to the equipment, the equipment switch must be turned "OFF" first, and then the reset button on the Sensing-Saf-Start® depressed. In the event the equipment is inadvertently unplugged and then plugged back into the power source while the equipment switch is in the "ON" position, the equipment will not restart until the reset button on the Sensing-Saf-Start® is depressed.



SCOPE OF APPLICATIONS AND STANDARDS - The Sensing-Saf-Start® is intended for installation on equipment which operates on 120-volts or 240-volts A.C. and which is connected to the source of electric power by means of a 3-wire flexible power cord.

The following standards apply to machines driven by 120 volt and 240 volt motors:

- **OSHA** (US Occupational Safety and Health Administration 29 DFR #1910.213 (b) (3)*)
- **NFPA** (Electrical Standard for Industrial Machinery, 1997 Edition, Section 8, Protection)

Sensing-Saf-Start® Installs In Minutes On:

- Drill Presses • Tool Grinders • Cut-Off Machines • Band Saws • Small Milling Machines
- Disc Sanders • Table Saws • Belt Sanders • Power Hacksaws • Radial Arm Saws

Now available in extension cord style or hard wire versions:

Model No. 17025, Short extension cord style. 14" cord on male plug end, 12" cord on female receptacle end. Rated 120 volts, A.C., 15-amp, 3/4 HP motor maximum, 50/60 cycle

Model No. 17023, 20" cord on equipment switch end. 8' cord on power end (no plug). Wire directly into disconnect box or install Twist Lock Plug. Rated 120-volt, A.C., 18-amp 1 H.P. motor maximum, 50/60 cycle

Model No. 17024, 20" cord on equipment switch end. 8' cord on power end (no plug). You must install matching plugs. Rated 200 to 240-volt A.C., 15-amp (single phase) 2 H.P. maximum, 50/60 cycle

MILLING MACHINE BELT COVERS



Cover closed.



Cover open

These unique patented belt covers are made of durable cast aluminum. The hinged covers are sold in pairs for the right and left sides and are permanently attached to the machine.

Spindle speed changes are done quickly and efficiently by simply pulling down the belt cover.

OSHA requires under 29 CFR 1910.219 that all mechanical power-transmission apparatuses on machinery that creates a hazard be covered up to meet this requirement.

These belt covers are made for Bridgeport model J.

Ordering Information: Model No. 13265, Model J Belt Covers with Hinges

Safety is our Specialty!



General Safety Company LTD.

Industrial Machines Safety: Components and Solutions

2175 Sheppard Ave. East Unit 250, Toronto, Ontario, M2J 1W8
Tel. (416) 645-0242 Fax. (416) 447-0091

INDUSTRIAL SAFETY MATS

General Safety Company LTD introduces its new line of premium Safety/Comfort Industrial Mats covering a wide range of usages. Rugged reliability designed for safety, comfort and increased productivity, mats are available for either wet/dry or dry-only environments.

I. Matting suitable for use on Wet, Moderately Greasy or Dry Floors

Reduce slip/fall accidents where wet, greasy floors and shop debris are present. Not only will matting improve shop safety but it's extremely comfortable and will reduce worker fatigue.

Drainage Safety Mats



- Mat design includes holes for drainage of fluids and collection of small debris from shop equipment
- Traction bars on surface help keep soles of shoes dry & clean
- Underside knobs help keep mat in place
- 100% all-purpose rubber construction
- Edges are safety beveled on all four sides; overall thickness of mat is 1/2"
- Color - Black

Model No. 13475 Drainage Safety Mat, 3' x 5'

Model No. 13476 Drainage Safety Mat, 3' x 10'

Model No. 13477 Drainage Safety Mat, 3' x 20'

Safety Bubble Matting

- Constructed of domed bubbles that the worker stands on allowing room for debris and fluids to settle
- Yellow ramped borders offer high visibility and promote safety
- Mat is molded using flexible natural rubber
- Overall mat thickness is 1/2"

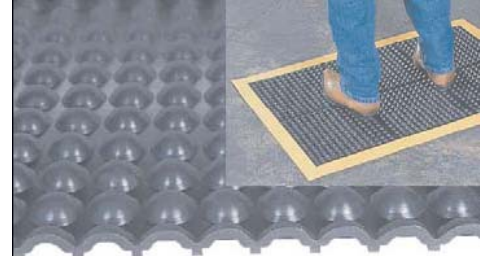

Model No. 13480 Safety Bubble Mat, 2' x 3'

Model No. 13481 Safety Bubble Mat, 3' x 4'

- Domed surface promotes blood circulation resulting in greater worker comfort and less fatigue
- Color - Black mat with Yellow borders on all four sides

II. Matting suitable for use on Dry Floors only.

These high visibility mats feature bright yellow borders and promote workplace safety while offering uncompromising comfort for the user.

ANTI-SLIP DIAMOND PLATE MATS

ANTI-FATIGUE WITH SAFETY BORDERS



- Mat is constructed of a tough vinyl surface permanently bonded to a soft sponge base
- Vinyl surface features molded in Diamond Plate pattern to promote secure footing
- Wide bright yellow borders accent visibility and ramped edges on all sides facilitate easy access and promote safety

Anti-Slip Mats Available in the Following Sizes:

Model No. 13485, 2' x 3' **Model No. 13488**, 3' x 75'

Model No. 13486, 3' x 5' **Model No. 13489**, 4' x 75'

Model No. 13487, 2' x 75'

- Deep sponge base offers a high comfort level; Goodbye fatigue!
- Due to rugged vinyl surface, this mat makes an excellent choice where multiple shifts are run
- Overall thickness is 9/16"
- Color - Black with Yellow Borders on longitudinal sides

Safety is our Specialty!



General Safety Company LTD.

Industrial Machines Safety: Components and Solutions

2175 Sheppard Ave. East Unit 250, Toronto, Ontario, M2J 1W8
 Tel. (416) 645-0242 Fax. (416) 447-0091

HALOGEN MACHINE LAMP

Heavy-Duty 50 Watt High Intensity Light... ideal on machines that flood the work area with coolants and heavy misting operations, heavy vibration, and high levels of flying metal objects.



FEATURES:

- 3" dia. extruded anodized aluminum lamp Head provides intense, accurate light disbursement to work area.
- On/Off Switch on lamp head.
- Superior chip-resistant tempered glass offers maximum operator safety - no protective guards needed.
- Large T-bar handle provides easy positioning.
- Minimal heat generation to the external casing of the fixture.
- Patented Flexbar flexarm positioner snakes into any position needed and locks rigid – no drift.
- Heavy-duty mounting bracket for easy mounting to machine casing.
- Uses replaceable 50 Watt Bulb.
- Includes heavy-duty 6 foot SJT cable with 12V external plug-in style AC power supply (UL Listed).

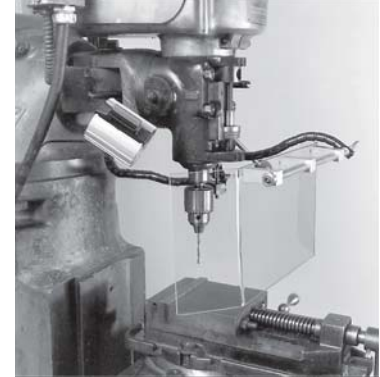

DIMENSIONS:

- Diameter of lamp head - 3".
 - Length of Flexbar arm - 15".
 - Ball joints - 17 each ($\frac{5}{8}$ " dia.).
 - Total reach to center of lamp head - approx. 18".
- Above: Halogen-Flexbar Machine Lamp mounted directly on Bridgeport - in use with Visorguard (See pages 12- 15).
 IDEAL FOR USE ON MANY OTHER TYPES OF MACHINES.

Model No. 15395, Halogen 50 Watt Machine Lamp Complete with mounting bracket and AC power supply.

Model No. 15396, 50 Watt replacement lamp for above

Model No. 80063-1, Replacement Flexbar Cable

COOL SHADE QUICK-COUPLER MACHINE LIGHT

Features

- Cool-to-the-Touch Double Wall Shade
- Gloss Black Color
- 6 Foot Grounded Cord, SJTO Oil Resistant Jacket
- 100 Watt Capacity for Bright Task Lighting (bulb not included)
- Versatile, Compact Quick-Coupler Mounting System Including Two Studs and Bracket for Any Mounting Surface, Horizontal or Vertical
- Heavy Duty Vinyl Covered Flexarm for Long Lasting Performance Available in 18" and 24" Lengths.



Cool Shade Multi-Lamps Also Available in Magnetic Base and C-Clamp Versions

Model No.	Description
15482	- Quick-Coupler w/18" Arm
15483	- Quick-Coupler w/24" Arm
15484	- Magnetic Base w/18" Arm
15485	- Magnetic Base w/24" Arm
15486	- C-Clamp Base w/18" Arm
15487	- C-Clamp Base w/24" Arm



Magnifier Attachment Accessory Model No. 15488

2x Magnifier with Shade. Attaches directly to lamp housing. Magnifier Dimensions: 2" x 4"

Safety is our Specialty!